

---

# Pressure1 Module

P/N: 81P-0110

---

Rev –  
8 AUG 2019

---

Graves Electronics, LLC

---

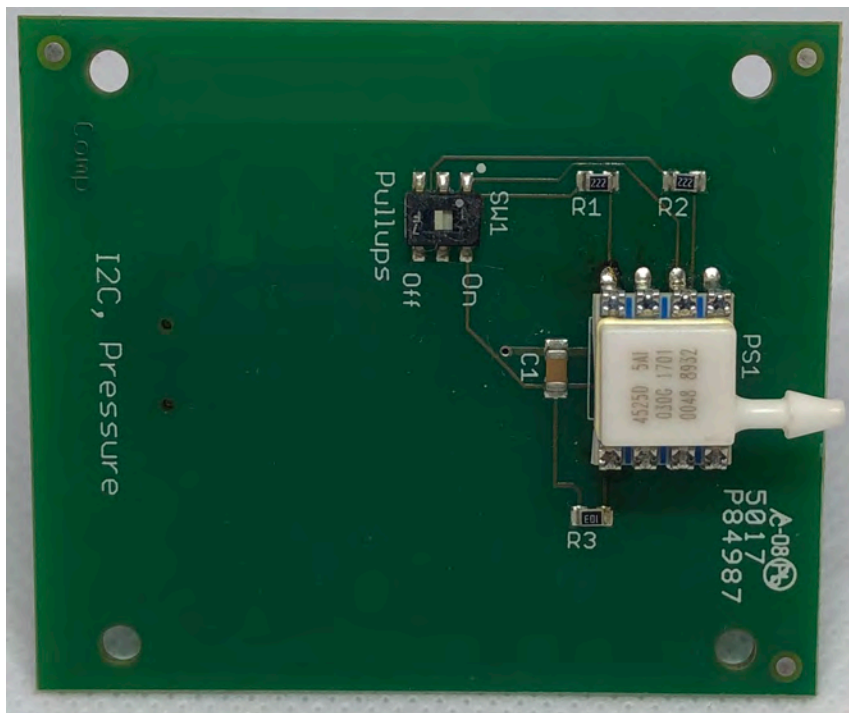

Symbols used in this manual:



**CAUTION:** This indicates a situation where if certain requirements are not followed, damage or unsafe conditions may occur.



**WARNING:** This indicates a situation where if certain requirements are not followed, damage or unsafe conditions WILL occur.



If you are having problems getting the board to work properly, BEFORE calling the factory, please visit the FAQ page at <http://www.graveselectronicsapps.com/faqs.html>, and/or thoroughly read section 9.0 of this manual. If you are still having problems, please download the test code from <http://www.graveselectronicsapps.com/downloads-.html> and run the code. If you are still having issues after reading the help section and trying the test code, please contact the factory. We kindly ask that you please e-mail us at [graveselectronics@gmail.com](mailto:graveselectronics@gmail.com). Please clearly state your problem along with a call back phone number. One of our technicians will call you after we have reviewed your issue and have come up with some solutions.

This manual, as well as test code, can be downloaded at <http://www.graveselectronicsapps.com/downloads-.html>.

Contact Information:

Customer Service, Sales, Technical Assistance

[graveselectronics@gmail.com](mailto:graveselectronics@gmail.com) or call us at 860-295-3074

Warranty & Legal:

Graves Electronics, LLC warrants that its products conform to the stated specifications. Graves Electronics, LLC warrants that its products will be free from material and manufacturing defects for the life of the product. Graves Electronics, LLC shall not be liable for any defects that are caused by neglect, misuse, or mistreatment by the customer, or third party, including improper installation or testing, or for any products that have been altered or modified in any way by the customer or a third party.

Graves Electronics, LLC products are not authorized for use in safety-critical applications where a failure of the product would reasonably be expected to cause severe personal injury or death. Safety-critical applications include, without limitation, life support devices and systems, equipment or systems for the operation of nuclear facilities, and weapons systems. Graves Electronics, LLC products are neither designed nor intended for use in military, aerospace, or automotive applications or environments. The customer acknowledges that use of Graves Electronics, LLC products is entirely at the customer's risk, and the customer agrees to defend, indemnify and hold harmless Graves Electronics, LLC from any and all damages, claims, suits, or expenses resulting from such use. The customer acknowledges and agrees that the customer is solely responsible for compliance with all statutory, legal, regulatory, and safety related requirements in regards to the usage of Graves Electronics, LLC products. In no event shall Graves Electronics, LLC be liable to the customer or any third party for any special, collateral, indirect, punitive, incidental, consequential, or exemplary damage in connection with, or arising from, the customer's software. The customer agrees to defend, indemnify and hold harmless Graves Electronics, LLC from any and all damages, claims, suits, or expenses resulting from said customer's software. Customer acknowledges that Graves Electronics, LLC reserves the right to change specifications on any product at any time without notice.

This document, related documents, drawings, technical specifications, designs, or operational information is the property of Graves Electronics, LLC



## Table of Contents

1.0	Overview .....	1
2.0	The Pressure Sensor .....	1
2.1	Transfer Function .....	1
	<i>Table 2.1. Sensor Output at Significant Percentages</i> .....	1
3.0	I <sup>2</sup> C Address .....	1
3.1	I <sup>2</sup> C Pull-Up Resistors .....	2
4.0	Installing the Module .....	2
5.0	Specifications .....	2
6.0	Block Diagram .....	3
7.0	Board Outline dimensions .....	4

## 1.0 Overview

The Pressure1 module is an easy to use pressure sensor module that increases the functionality of the 81 controller board. The module utilizes Honeywell's SSC line of digital pressure sensors. The module plugs into either of the module ports on the 81 controller board. The Pressure1 module uses the I<sup>2</sup>C bus to communicate with the microcontroller on the 81 board. It has DIP switch to engage or disengage pull-up resistors for the I<sup>2</sup>C bus.

## 2.0 The Pressure Sensor

The pressure sensor is a 12-bit, piezoresistive silicon sensor, calibrated over the temperature range of -20°C to +85°C, with a Full Scale Span of ±0.25%. Total Error Band is 2%. The sensor measures 0-100 psi, gauge pressure. The sensor has a barbed port that is 0.194", which is suitable for most commercially available ¼" tubing.

### 2.1 Transfer Function

The transfer function defines the output of the sensor at a given pressure input. It is found by the following equation:

$$\text{Output (\% of } 2^{14} \text{ counts)} = \frac{80\%}{P_{max} - P_{min}} * (Pressure_{applied} - P_{min}) + 10\%$$

**Table 2.1. Sensor Output at Significant Percentages**

% Output	Digital Counts (decimal)	Digital Counts (hex)
0	0	0x0000
10	1638	0x0666
50	8192	0x2000
90	14746	0x399A
100	16383	0x3FFF

## 3.0 I<sup>2</sup>C Address

The module uses I<sup>2</sup>C address 0x58. For more information on the I<sup>2</sup>C bus, please consult NXP document [UM10204](#).

### 3.1 I<sup>2</sup>C Pull-Up Resistors

In order for the I<sup>2</sup>C bus to work correctly, it must have pull-up resistors on the SDA and SCL lines. The module makes that easy through the use of switch SW1. When the switch is in the “On” position (as labeled on the module), two 2.2K Ohm resistors are switched in to the I<sup>2</sup>C bus; one on the SDA line and one on the SCL line. When the switch is in the “Off” position, the pull-up resistors are switched out of the circuit. If only one module is being used, it must have the pull-up resistors switched on. If two modules are being used, only one module needs to have the I<sup>2</sup>C pull-up resistors switched on. It does not matter which module has the resistors switched on.



**CAUTION:** Failure to switch on the I<sup>2</sup>C pull-up resistors could result in erratic operation of the I<sup>2</sup>C bus, and consequently, erratic operation of the module!

**CAUTION:** If using two modules, switching on the I<sup>2</sup>C pull-up resistors on BOTH modules could result in erratic operation of the I<sup>2</sup>C bus, and consequently, erratic operation of the module! When using two modules, switch on only ONE I<sup>2</sup>C pull-up!

### 4.0 Installing the Module

Installation of the Pressure1 module is extremely easy. First, decide which module port on the 81 board the module will plug into. The module communicates over I<sup>2</sup>C to the microcontroller, so for communications purposes, it does not matter which module port is utilized. Pick the port that is most convenient for mechanical or aesthetic reasons. Remove the black protective header cap off of the header on the main board. Carefully align J1 of the module with the header on the module port. Push down until the module is fully seated onto the header. The module is fully seated when the module is touching the four standoffs on the module port. Use the four 4-40 x ¼ Philips pan head screws supplied with the module to secure the module. The tightening torque is a minimum of 2.6 in-lbs. and a maximum of 16.6 in-lbs. **DO NOT EXCEED 16.6 IN-LBS!**

### 5.0 Specifications

Symbol	Parameter	Condition	Min	Typ	Max	Unit
TEMP <sub>OP</sub> <sup>1</sup>	Operating Temperature	-	-40	-	+85	°C
TEMP <sub>COMP</sub> <sup>2</sup>	Compensated Temperature Range	-	-20	-	+85	°C
t <sub>START</sub>	Start-up Time	Power up to data ready	-	-	3	ms
t <sub>RESPONSE</sub>	Response Time	Under pressure	-	0.46	-	ms
FSS <sup>3</sup>	Accuracy	Under pressure	-	-	±0.25	%
RESOLUTION	Output Resolution	-	12	-	-	Bits
P <sub>MIN</sub>	Pressure- Minimum	-	0	-	-	psi
P <sub>MAX</sub>	Pressure-Maximum	-	-	-	100	psi
P <sub>OVER</sub>	Over Pressure	Under pressure	-	-	250	psi
P <sub>BURST</sub> <sup>4</sup>	Burst Pressure	Under pressure	-	-	250	psi

FSS <sub>(TOTAL ERROR)</sub> <sup>5</sup>	Total Error Band	Under pressure	-	-	±2	%
	Long Term Stability (% of FSS)	1000 hrs @ 25°C	-	-	±0.25	%

<sup>1</sup> Operating Temperature Range is the range over which the sensor will produce an output proportional to pressure.

<sup>2</sup> Compensated Temperature Range is the range over which the sensor will produce an output proportional to pressure within the specified performance limits.

<sup>3</sup> FSS (Full Scale Span) is the algebraic difference between the output signal when measured at Pressure (max) and Pressure (min).

<sup>4</sup> Once sensor is subject to burst pressure, the sensor should be considered damaged and must be replaced.

<sup>5</sup> Total Error Band is the maximum deviation from the ideal transfer function over the entire compensated range. It includes all errors due to offset, full scale span, pressure non-linearity, pressure hysteresis, repeatability, thermal effect on offset, thermal effect on span, and thermal hysteresis.

## 6.0 Block Diagram

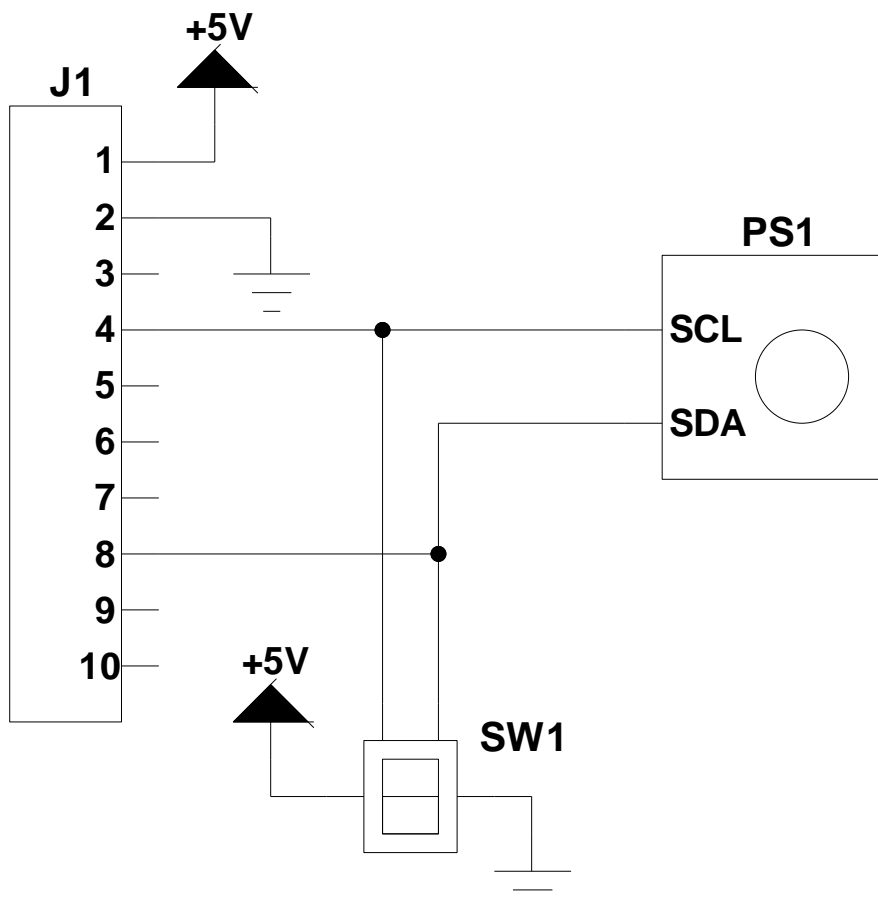

## 7.0 Board Outline

