

Product Data Sheet

135X701

Power Distribution Block –
Splicer Type
UL Listed
Category QPQS
475 Amps, 600 Volts (AC/DC)



Provides Feeder Circuit Terminal Spacing up to 600 Volts per UL 508A, Section 10.

Wire Range:

Line Side: (1) 750kcmil – 1/0 AWG

Load Side: (1) 750 kcmil – 1/0 AWG

[See tables below for SCCR wire ranges, flexible stranded and multiple wire approvals.](#)

Electrical Ratings:

- 475A copper wire, 385A aluminum wire (Based on NEC Code, 75°C columns)
- UL Voltage Rating: 600 Volts AC/DC (UL 1953)
- Factory and Field Wiring

Agency Certifications:

- UL Listed, Investigated to UL 1953, File QPQS.E309401
- RoHS Compliant

Short Circuit Current Ratings:

SCCR Rating applies for Copper Stranded wire only

UL Class B, C (known as Rigid Stranded, Building Wire, Code Wire)

UL Class G, H, I (Flexible Stranded, includes DLO)

Suitable Conductors (kcmil/AWG)				Overcurrent Protection Fuse						SCCR, RMS SYM/Amps	Volts Max
Copper, Stranded				Class/Max Amp Rating							
Line		Load									
Size	Class	Size	Class	J	T	RK1	RK5	G	CC		
750-1/0	BC	750-1/0	BC	600	1200	600	400	60	30	100,000	600
535-1/0	GHI	535-1/0	GHI	600	700	600	200	60	30		

For DC power or any wire combinations or Overcurrent Protection not shown- SCCR is 10,000A

Minimum Enclosure Size: 20" x 24" x 8" (3840 cu. In)

Mechanical Ratings:

- Maximum insulator base temperature: 125°C (257°F) UL RTI
- Flammability rating of insulator base: UL 94 V-0

Materials:

- Connector: High conductivity aluminum, tin plated
- Insulator base: Glass filled polycarbonate (thermoplastic)
- Terminal screws: Aluminum, tin plated
- Connector mounting screw: Steel, zinc plated

Wire Ranges, Wire Types, Torque Ratings: 135X701

UL Class B, C (known as Rigid Stranded, Building Wire, Code Wire)

UL Class G, H, I (Flexible Stranded, includes DLO)

Line Side 1) 750 kcmil - 1/0 AWG

Copper Conductor			
Wire Size	Torque		UL Class
kcmil - AWG	N.m	in. lbs	
750 - 1/0	67.8	600	B, C
535 - 1/0	67.8	600	G,H,I
Aluminum Conductor			
Wire Size	Torque		Type
kcmil - AWG	N.m	in. lbs	
750 - 1/0	67.8	600	Stranded

Load Side 1) 750 kcmil - 1/0 AWG

Copper Conductor			
Wire Size	Torque		UL Class
kcmil - AWG	Nm	in. lbs	
750 - 1/0	67.8	600	B, C
535 - 1/0	67.8	600	G,H,I
Aluminum Conductor			
Wire Size	Torque		Type
kcmil - AWG	Nm	in. lbs	
750 - 1/0	67.8	600	Stranded

Installation & Accessories:

- Line side 750 kcmil wire opening = 1.125 (28.5mm) diameter
Wire Strip Length = 1 3/4"
- Load Side 750 kcmil wire opening = 1.125 (28.5 mm) diameter
Wire Strip Length = 1 3/4"
- Mounting (Panel)
For use with 1/4" fasteners (4) pole
Torque mounting fasteners to 30 lb-in (3.4mm)
- Covers (sold separately)
Catalog number – CH135X
Accessory covers are not intended to provide insulation for electrical spacing

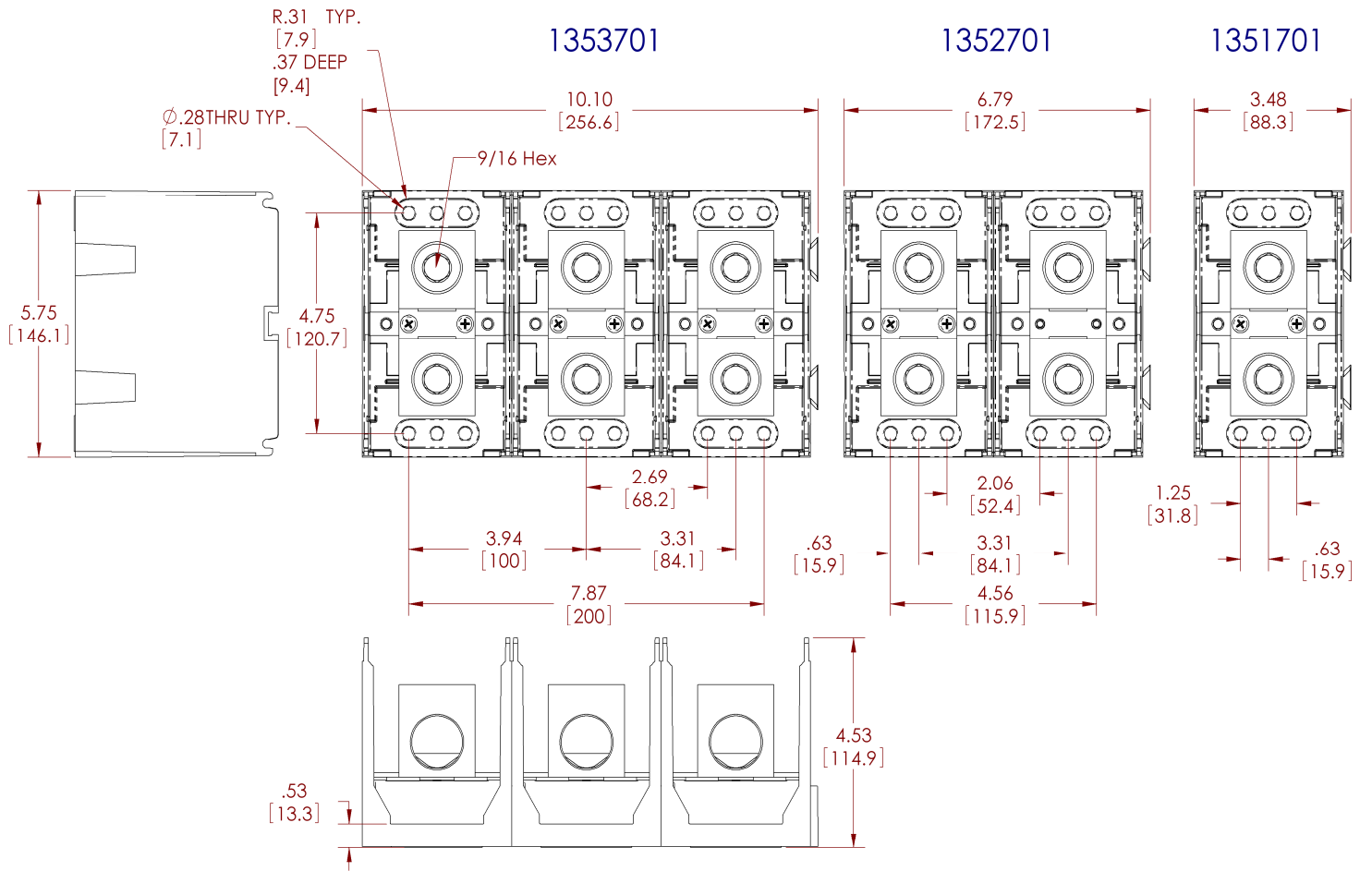

WWW.MARATHONSP.COM
 1-419-352-8441